

High Speed Labeler

Collamat® 9110 i

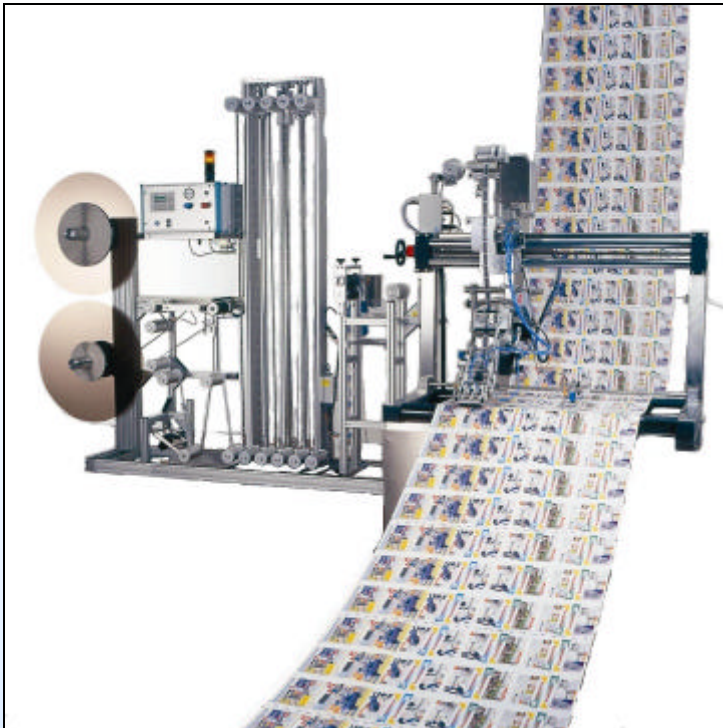

Collamat® 9110 i mono with splicer

The solution for promotional labeling

Collamat® 9110 i for:

- Speed up to 250 m/min
- labels 54 000 per hour
- Precision accuracy +/-1,5 mm
- Non-stop labeling
- Tandem labeling with more than 100 000 labels per hour
- Dimensions customized to web line
- Highest performance on the market
- References available

Applications

- in line direct on the paper web
- graphic printing lines
- direct mailings
- product promotion:
 - perfume samples
 - scratch-off competitions
 - lottery tickets
- piggy-back label with a membership card or offer



High Speed Labeler

Collamat® 9110 i

Features

- **Modular design**
 - for easy integration in a production line
- **High Speed**
 - Maximal utility of web line
- **High precision**
 - over the whole speed range for satisfied customers
- **Non-stop operation**
 - automatic switch over when Two Collamat® 9110 i installed
- **Non-stop production control**
 - not missing a product
 - not labelling a product twice.
- **Compact design**
 - minimal space needed
- **In-line mounting standards**
 - suited to web lines.
- **Easy handling**
 - minimal set-up time
 - saves manpower
- **High quality labeler**
 - works efficiently with all label materials at High speed. Swiss quality means uniform performance over the years
- **No paper tear**
 - due to special Collamat development tension in liner paper is massively reduced

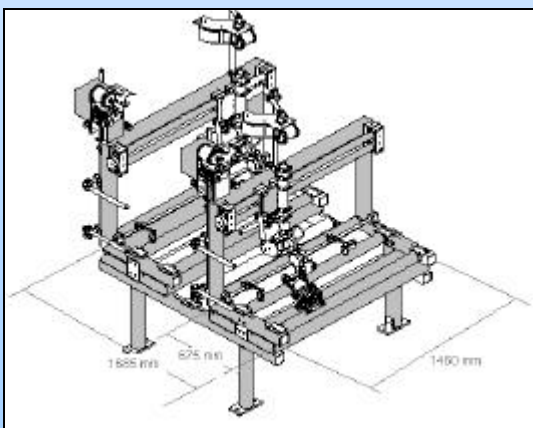

Technical Data

Collamat – technical data

Product scanning:

Black mark, length 4 mm x width 8 mm, pre-printed on the side of the form

Technical data:

Labels:

- Width between 40 to 90 mm
- Length from 20 to 100 mm,
- Label shape: rectangular

Label roll:

- Max. 400 mm outer-diameter,
- Core-diameter 3".

Label positioning:

- From top to the form.

Speed:

- Min. Labeling speed: 3 m/Min.
- Max. Labeling speed: up to 250 m/Min (depending on the label specification).

Accuracy:

- Up to 250 m/min. \pm 1.5 mm depending on label specification

Capacity:

- Max. 54'000 labels per hour. Mono system (related to the label length and label width)

Operation mode:

- Mono
- Non-Stop
- Tandem

Power requirements:

- 220/240 V / 50 Hz, or 110 V / 60 Hz.
- Air: pressure 6 bar needed, provided on site.

Approbation CE/IEC/Nema

Technical features and/or design is subject to change without prior notice.

For local distributor call:

Collamat Stralfors AG

Pfeffingerring 201
CH-4147 Aesch
Phone: ++41 (0)61 756 28 28
Fax: ++41 (0)61 756 29 29



Swiss Modular Labelers

Visit our homepage:
<http://www.collamat.ch>